

FUELEQUIPMENT.COM

Custom *fuelling* solutions

Conventional single skinned diesel fuel trailers

Available in capacities 1000, 2000 and 3500 litres single and load-sharing tandem axles, these trailers are a tried and tested design incorporating many safety and functional features. Available fitted with a wide range of dispensing systems and optional equipment to suit almost any requirements. Used by Councils, farmers, contractors, civil construction Companies, State & Federal Government bodies nationwide and in many other countries, these trailers are adaptable and configurable for a vast range of applications. Can be fitted with engine-powered, manual, pneumatic and DC pump systems

1000 Litre Diesel Fuel Trailer

Australian designed & manufactured



1000 litre registerable trailer fitted with optional DC pump system in lockable enclosure and full-width toolbox. Trailers are manufactured with all facilities to fit either a manual pump, a DC powered pump system or an engine powered system.

- Lockable tool/equipment box.
- 50mm ball hitch with handbrake lever & safety chain, 7 pin electrical plug.
- Epoxy 2 part enamel paint finish
- Vent with double elbow & ball valve for spill-free travel when full

Australian Fuelling Systems & Equipment

PO Box 7162 NEMSC 2348 7-11 Armstrong Street Tamworth 2340
Ph: +61 2 6760 7816 Fax: +61 2 6760 7826

www.fuelequipment.com

Australian
FUELLING
Systems & Equipment

FUELEQUIPMENT.COM

Custom fuelling solutions

2000 Litre Diesel Fuel Trailer

The most sought model within our range, the 2000 litre unit comes in at less than 3000kgs when fully laden. This allows legal and safe towing by a wide range of vehicles. Its low profile and low centre of gravity makes this an ideal fuelling vehicle when you have to cover larger distances, ideal for larger country Councils, contractors and whenever your work keeps you moving. Low profile allows easier and safer access to tank top fittings for filling and dipping. Can be fitted out for any application.

5 Year Tank Warranty



2000 litre registerable trailer fitted with optional 5hp petrol engine-powered pump system with flowmeter and 30 micron filter.

- The trailer is manufactured with all facilities to fit either a manual pump, a DC powered pump system or the engine powered system at front as shown (petrol or diesel available)
- Lockable tool/equipment box.
- 50mm ball hitch with handbrake lever & safety chains, 12 pin electrical plug.
- Epoxy 2 part enamel paint finish
- Heavy duty load-sharing tandem suspension system

Warranty

All equipment & workmanship fitted and included with these trailers are covered by 12 months warranty with additional 4 years (total 5 years) warranty on the tank. Warranty is limited to repair or replacement at our discretion and excludes normal wear & tear and physical damage caused by accident or neglect or other third party causes. No responsibility is accepted or implied for any consequential, third party damage or loss of product. Please read and implement all safety and maintenance requirements shown in operators manual.

Australian Fuelling Systems & Equipment

PO Box 7162 NEMSC 2348 7-11 Armstrong Street Tamworth 2340

Ph: +61 2 6760 7816 Fax: +61 2 6760 7826

www.fuelequipment.com

Australian
FUELLING
Systems & Equipment

FUELEQUIPMENT.COM

Custom fuelling solutions

3500 Litre Diesel Fuel Trailer



This vehicle is the largest capacity possible to build with a gross mass of less than 4500kg - at which point more complex and expensive build regulations apply.

- There are a large range of options available for this vehicle (grader tips, gensets, water tanks, larger toolboxes, grader tyre holder etc) but the weight of each must be deducted from the fuel volume. Example - if you wish to fit a 200 litre stainless water tank to the trailer - we reduce the diesel volume by 240 litres to accommodate the extra weight. This is done by reducing the tank length.
- This vehicle differs from the smaller units in that the tank is a separate entity from the vehicle frame - to which it is attached by spring-loaded brackets. This allows the vehicle to flex without stressing the tank.
- Can be fitted with a variety of hitch system to suit your towing vehicles - these include pintle hooks, fixed or swivelling rings or a 70mm heavy duty ball. The trailer can be built to accommodate multiple hitch types - (see above) by providing the different system built onto a bolt-on plate which can be easily changed.
- Can also be engineered to have adjustable tow-hitch heights if required.

Registration

We do not register these trailers on your behalf. However, we do provide pink or blue slips proving compliance and suitability for registration within NSW as well as a weighbridge ticket. The rules/standard to which they are built is a National standard so that compliance in NSW applies nationally - but may require inspection in your State or Territory.

Relevance of AS2809

Currently, within Australia, there is no requirement for diesel trailers (with dual walled tanks or single skin tanks) to be built in accordance with AS2809. Indeed, there is no legal requirement for any vehicle to be double-walled self-bunded, these vehicles have recently grown popular as a means to ensure to the highest level, that all risk of spillages are minimised.

Electrical connections

Any trailer with a gross mass of greater than 2000 kgs must be fitted with a breakaway switch and associated equipment (includes onboard battery, charge status indicators etc). VSB1 requires that these vehicles be fitted with circuits for indication of charges status to the driver whilst in the drivers seat. This requires the installation of a 12 pin flat electrical connection system. Trailers less than 2000kg are fitted with 7 pin connection

www.fueltrailer.com

FUELEQUIPMENT.COM

Custom fuelling solutions

Dispensing Systems

DC Pump systems - 12 or 24v

Includes:

12 or 24v vane pump with integral bypass valve (Various models available)

- Suction assembly - telescopic
- 3.6m delivery hose
- Manual trigger nozzle with swivel
- 5m x 6mm battery cables with clips & inline fuse

Options (NB addition of options will decrease flows)

- Filter - Goldenrod 10 micron with see-thru bowl & drain cock
- Flowmeter - with 3 digit reset register and 6 digit non-reset totaliser
- Longer delivery hose
- Automatic nozzle - Catlow automatic with low back-pressure to maximise flow & fitted with swivel

Nett flow from nozzle from above system approximately 40 - 45 lpm



Engine-powered - ULP or diesel

Includes:

- Villiers 5hp ULP engine - recoil start
- Close-coupled self-priming centrifugal pump - 38mm
- Suction assembly with strainer, valve & Kamlok connection
- Pump to reel hose assembly with fittings & Kamlok connection
- Manual rewind hose reel
- 6m x 32mm T650-32 rubber delivery hose & fittings
- Catlow NM1 25mm high flow auto nozzle with swivel

Options

- Filter, 38mm CimTek 30 micron with spin-on element
- Flow meter - 38mm with 4 digit reset register & 6 digit non-reset totaliser
- Spring rewind hose reel
- Honda GX160 engine in lieu of Villiers
- Villiers 5hp diesel engine with electric start in lieu of Villiers ULP engine

Nett flow from above system approximately 125-130 lpm



Manual Pump

The GP RAPIDFLO™ is a durable impeller pump incorporating a gearbox for high output (up to 100 L/min) and easy operation. Designed for 205 L (55 US gal) or 60 L (16 US gal) drums, this pump is ideal for high volume fuel transfer.

Features

- pumps easily in both directions
- 2.4 m (8 ft) anti-static rubber delivery hose and nozzle
- 1.06 m (3.5 ft) two-piece threaded suction tube
- lockable handle and built-in nozzle holder
- built-in strainer
- 50 mm (2") bung adaptor
- GP-01-BD biodiesel version also available
- fully serviceable
- 10 year warranty and parts guarantee



Australian Fuelling Systems & Equipment

PO Box 7162 NEMSC 2348 7-11 Armstrong Street Tamworth 2340

Ph: +61 2 6760 7816 Fax: +61 2 6760 7826

www.fuelequipment.com

**Australian
FUELLING
Systems & Equipment**

FUELEQUIPMENT.COM

Custom fuelling solutions

Conventional Trailer Specifications

	1000 litre	2000 litre	3500 litre
Dimensions	3150Lx2020Wx1560H	4330Lx2020Wx1560H	4500Lx2290Wx1620H
Mass (tare)	500kgs	820kgs	1250kgs
Mass (laden)	1350kgs	2480kgs	4250kgs
Brakes	Electric	Electric with breakaway	Electric with breakaway
Axle size & capacity	45mm sq - 1450kgs	45mm sq x 2 - 2900kgs	63mm sq x 2 - 6000kg
Plug connection type	7 pin round	12 pin flat	12 pin flat
Lights	LED	LED	LED
Wheels/stud pattern	15" Sunraysia/6 stud LC	15" Sunraysia/6 stud LC	16" Sunraysia/6 stud LC
Tyres	31x10.50R15	31x10.50R15	265/75R16
Tank capacity	1030 litres	2000 litres	3600 litres
Safe Fill Level @ 95%	1000 litres	1950 litres	3500 litres
Spill kit in lockbox	Yes	Yes	Yes
Fire extinguisher	9kg ABE with Bracket	9kg ABE with bracket	9kg ABE with bracket
Lockable pump cabinet	Option	Option	Option
Dipstick	20x20x3mm black anodised aluminium		
Fill tube	50mm with lockable cap		
Tow hitch	50mm ball 3500kg	50mm ball 3500kg	See options
Snap-lok jockey wheel	Yes	Yes	Yes
Spare wheel & bracket	Option	Option	Option

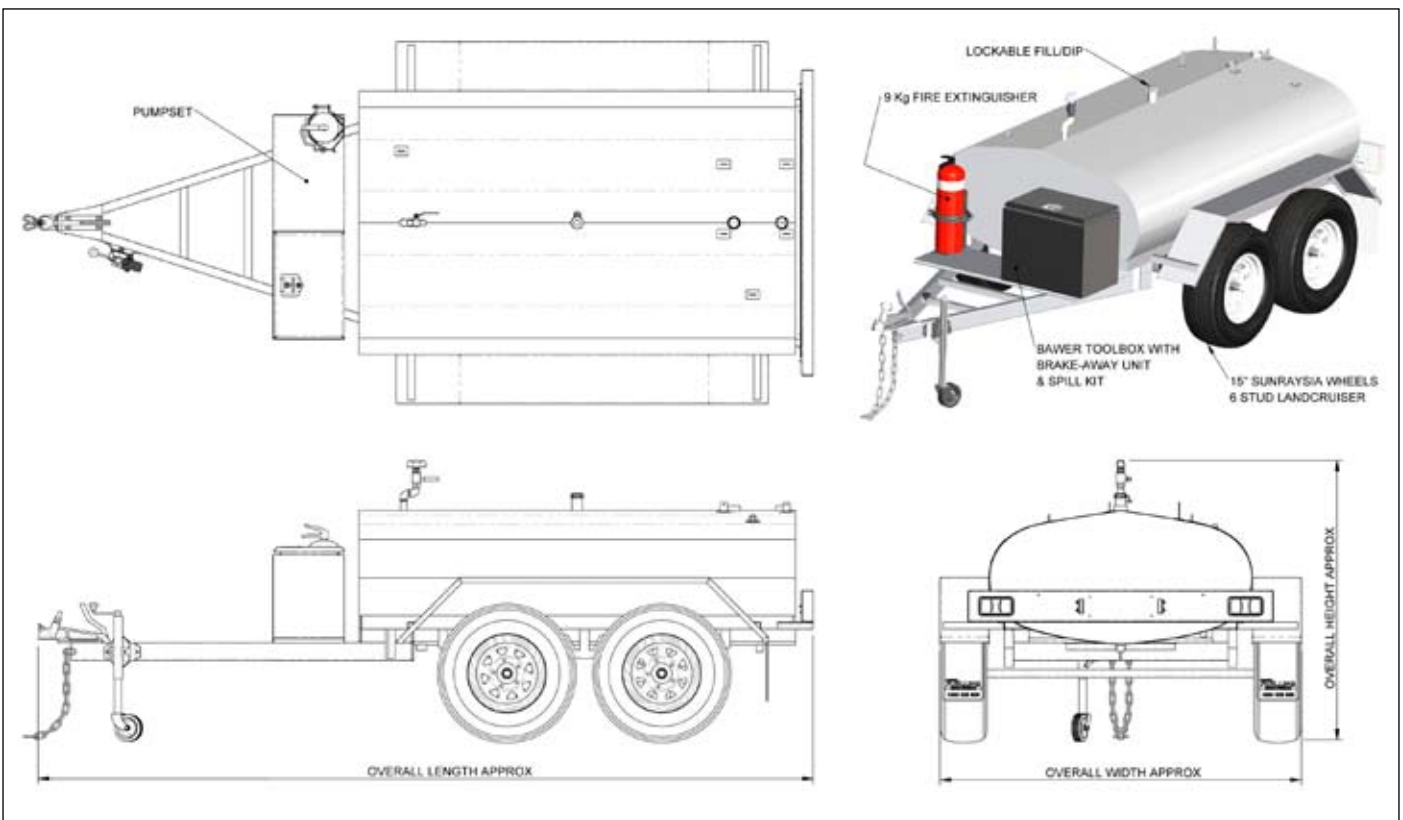

www.fueltrailer.com

FUELEQUIPMENT.COM

Custom fuelling solutions

Pump Systems

Inventory No	Description	System Price
020108	Macnaught GP geared rotary	
035001	12v DC pump system	
035002	12v DC economy pump system	
035002	24v DC pump system	
035003	Petrol engine-powered pump system	
035004	Diesel engine-powered pump system	
115000	Hose reel spring rewind for DC systems 10m x 25mm hose	
115002	Hose reel geared manual rewind for engine systems 10m x 32mm	
115003	Solar power system for DC pumps - (35w panel, 65aH battery, reg & wiring)	

Other Trailers in our Range



Dog trailer 10,000L DG Approved for Flammables - 1,2 and 3 comp.



Dangerous Goods Approved trailers for Class 3 Flammables - Petrol, AvGas, Jet-A1.



Aviation fuel quality test & hydrant pit cleaning



Tri-compartment transformer oil with special 2 way pumping equipment



Dog trailers for diesel - reg'ble & unreg'ble



Conventional diesel trailers in 1k, 2k and 3500L versions. Reg'ble & unreg'ble with range of pumpsets

About us:

We've been building fuel trailers in Tamworth, NSW, using Australian craftsmen & materials since the late 1980's - we made many mistakes, but after the first fifteen years we got to the stage where we believe we get most things right. We have designs & models for a whole range of fuel & oil handling trailers - these range from aviation refuellers, waste oil collection, special transformer oil vehicles, dog-type trailers with capabilities & volumes up to 10,000 litres for carriage of Class 3 Flammable Liquids. We even have a very task-specific vehicle which has all requirements to clean out aviation fuel hydrant pits & test the quality of the fuel at each point.

Queries:

If you have any queries on our self-bunded range or any of the other types, please call 1800-025 869 or email sales@fuelequipment.com

Australian Fuelling Systems & Equipment

PO Box 7162 NEMSC 2348 7-11 Armstrong Street Tamworth 2340

Ph: +61 2 6760 7816 Fax: +61 2 6760 7826

www.fuelequipment.com

Australian
FUELLING
Systems & Equipment