

FUELEQUIPMENT.COM

Custom *fuelling* solutions

Self-Bunded Diesel Fuel Trailers



Australian designed & manufactured

A solution for transporting and dispensing fuel to machinery & equipment in environmentally sensitive areas, these trailers incorporate strategies and systems to minimise the risk of both accidental and operational spillage of diesel fuel. The solid dual-walled tank construction, spill collection sumps and integral protective equipment provides a well balanced and economical fuelling system when risk of spillage needs to be minimised.

Trailer shown with optional diesel engine-powered pump system



Features

- Dual-wall tank construction
- Outer tank will contain 110% of inner tank
- Interstitial space monitor
- Rollover protection coaming with lockable & weatherproof cover
- Pressure & vacuum vent with rollover valve (closes valve if tank inclines greater than 60deg)
- All fluid out is via an anti-siphon valve
- Spill containment at fill and pump locations (both fitted with drain valves)
- Lockable enclosures secures all pumping equipment and fill/dip points
- Spill kit and 9kg fire extinguisher included
- Lockable tool/equipment box standard
- Choice of engine-powered or DC pump systems

Australian Fuelling Systems & Equipment

PO Box 7162 NEMSC 2348 7-11 Armstrong Street Tamworth 2340

Ph: +61 2 6760 7816 Fax: +61 2 6760 7826

www.fuelequipment.com

**Australian
FUELLING
Systems & Equipment**

FUELEQUIPMENT.COM

Custom *fuelling* solutions

1000 Litre Self-Bunded Diesel Fuel Trailers



Australian designed & manufactured

Self-Bunded Diesel Fuel Trailers



Rear view - cabinet closed

Designed for ultimate safety

Our double-walled self-bunded trailers are built to incorporate many features of AS1940-2004 - which is the standard for static self-bunded tanks.

- The outer tank will contain 110% of the inner tank,
- All fluids out are through an anti-siphon valve,
- There are no orifices out of the tank below Safe Fill Level
- There is a large spillage collection sump under pump system - this containment is fitted with a drain valve.
- Fill/dip tube & vent inside rollover coaming with lockable lid & drain valve

Australian Fuelling Systems & Equipment

PO Box 7162 NEMSC 2348 7-11 Armstrong Street Tamworth 2340

Ph: +61 2 6760 7816 Fax: +61 2 6760 7826

www.fuelequipment.com

Australian
FUELLING
Systems & Equipment

FUELEQUIPMENT.COM

Custom fuelling solutions

Self-Bunded Diesel Fuel Trailers

Lockable rear pump enclosure. Lift-up door with gas strut assist allows full & easy access to pump equipment. Has deep well for collection of any spills - ball valve drain makes cleaning simple. Enclosure opening fitted with pinch-weld rubber sealing for dust exclusion.



Shown with optional diesel engine-powered pump system

Anti-siphon valves

An anti-siphon valve reduces the risk of diesel siphoning out through the pump system in case of a drive-away or other malfunction. They are expensive and do reduce flows from the pump system but the added protection makes sense when considered within the overall cost of a self-bunded trailer.

5 Year Tank Warranty

Relevance of AS2809

Currently, within Australia, there is no requirement for diesel trailers (with dual walled tanks or single skin tanks) to be built in accordance with AS2809. Indeed, there is no legal requirement for any vehicle to be double-walled self-bunded, these vehicles have recently grown popular as a means to ensure, to the highest level, that all risk of spillages are minimised.

Electrical connections

Any trailer with a gross mass of greater than 2000 kgs must be fitted with a breakaway switch and associated equipment (includes onboard battery, charge status indicators etc). VSB1 requires that these vehicles be fitted with circuits for indication of charges status to the driver whilst in the drivers seat. This requires the installation of a 12 pin flat electrical connection system. Trailers less than 2000kg are fitted with 7 pin connection

www.fueltrailer.com

FUELEQUIPMENT.COM

Custom fuelling solutions

3000 Litre self-bunded Trailer

Weatherproof lockable equipment cabinet with large capacity spill collection with drain valve

Built to achieve a gross mass less than 4500kg - at which point much more complex build rules apply, this vehicle can be fitted with a ring-hitch, 70mm 6000kg ball hitch or pintle hook to suit your towing vehicle.

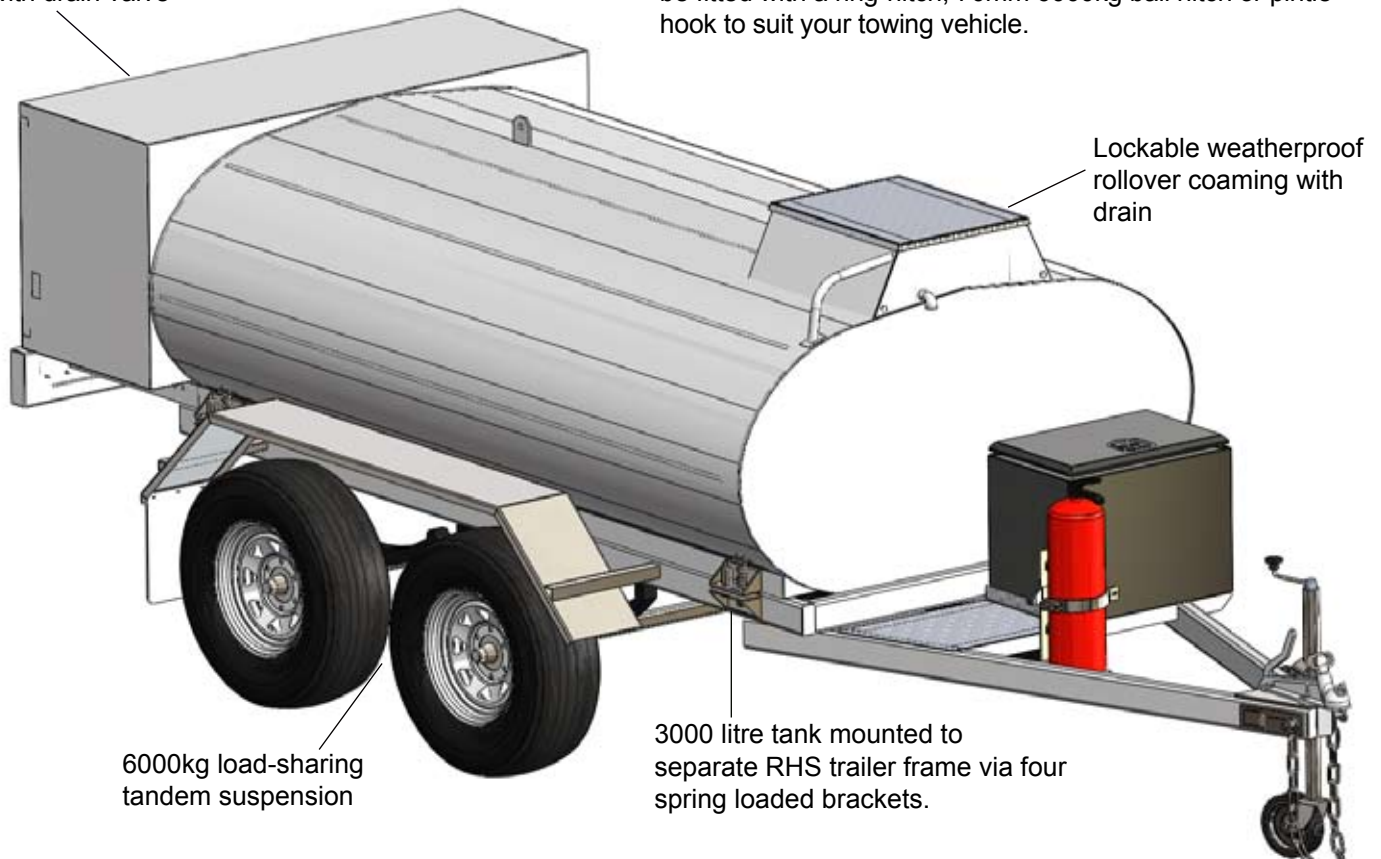

Lockable weatherproof rollover coaming with drain

6000kg load-sharing tandem suspension

3000 litre tank mounted to separate RHS trailer frame via four spring loaded brackets.

Details for engine-powered pump systems

Engine-powered pump system - built onto steel frame for easy installation & removal for service

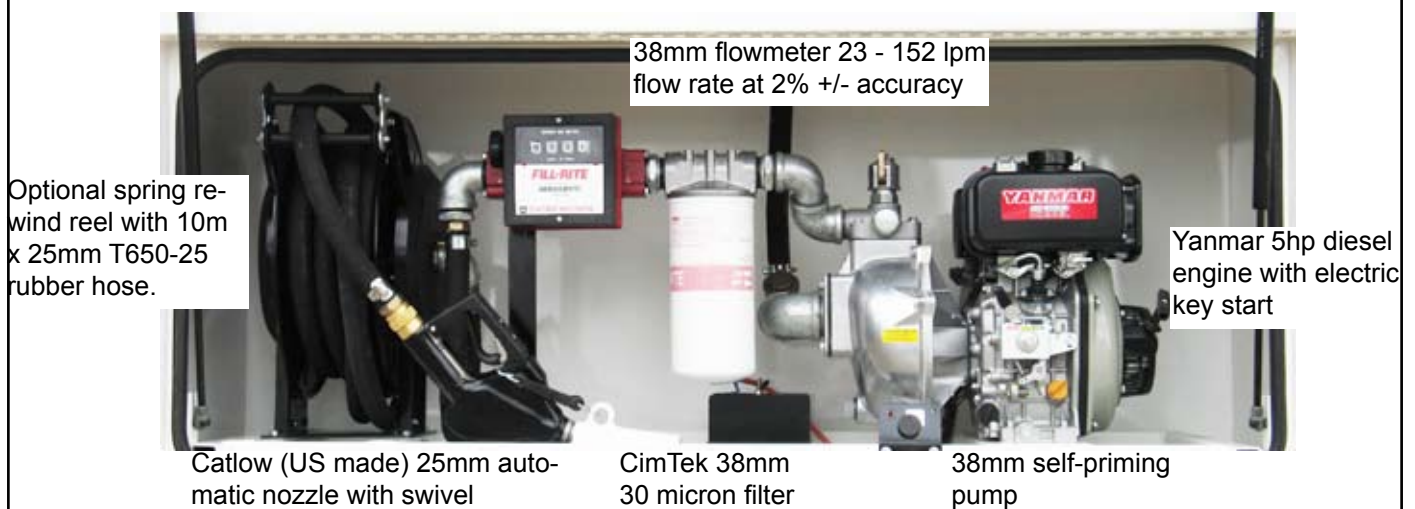

38mm flowmeter 23 - 152 lpm flow rate at 2% +/- accuracy

Optional spring re-wind reel with 10m x 25mm T650-25 rubber hose.

Yanmar 5hp diesel engine with electric key start

Catlow (US made) 25mm automatic nozzle with swivel

CimTek 38mm 30 micron filter

38mm self-priming pump

Australian Fuelling Systems & Equipment

PO Box 7162 NEMSC 2348 7-11 Armstrong Street Tamworth 2340

Ph: +61 2 6760 7816 Fax: +61 2 6760 7826

www.fuelequipment.com

**Australian
FUELLING
Systems & Equipment**

FUELEQUIPMENT.COM

Custom fuelling solutions

Dispensing Systems

DC Pump systems

Includes: 12 or 24v vane pump with integral bypass valve
 Suction assembly connecting anti-siphon valve to pump, includes strainer
 Filter - Goldenrod 10 micron with see-thru bowl & drain cock
 Flowmeter - with 3 digit resettable register and 6 digit non-resettable totaliser
 Hose storage - manual rewind hose reel
 Hose - 6m x 25mm T650-25 rubber delivery hose & fittings
 Nozzle - Catlow automatic with low back-pressure to maximise flow & fitted with swivel
 Nett flow from nozzle from above system approximately 40 - 45 lpm



Engine-powered ULP

Villiers 5hp ULP - recoil start

Close-coupled self-priming centrifugal pump - 38mm
 Suction assembly with strainer, connected through anti-siphon valve
 Filter, 38mm CimTek 30 micron with spin-on element
 Flow meter - 38mm with 4 digit resettable register & 6 digit non-resettable totaliser
 Hose storage - manual rewind reel
 Hose - 6m x 32mm T650-32 rubber delivery hose & fittings
 Nozzle - Catlow NM1 25mm auto nozzle with swivel
 Nett flow from above system approximately 125-130 lpm



Engine-powered Diesel

Yanmar 5hp diesel with electric key start

Close-coupled self-priming centrifugal pump - 38mm
 Suction assembly with strainer, connected through anti-siphon valve
 Filter, 38mm CimTek 30 micron with spin-on element
 Flow meter - 38mm with 4 digit resettable register & 6 digit non-resettable totaliser
 Hose storage - manual rewind reel
 Hose - 6m x 32mm T650-32 rubber delivery hose & fittings
 Nozzle - Catlow NM1 25mm auto nozzle with swivel
 Nett flow from above system approximately 125-130 lpm



Pump Systems

Inventory No	Description	System Price
035001	12v DC pump system	
035002	24v DC pump system	
035003	Petrol engine-powered pump system	
035004	Diesel engine-powered pump system	
115000	Hose reel spring rewind for DC systems 10m x 25mm hose	
115002	Hose reel geared manual rewind for engine systems 10m x 32mm	
115003	Solar power system for DC pumps - (35w panel, 65aH battery, reg & wiring)	

www.fueltrailer.com

FUELEQUIPMENT.COM

Custom fuelling solutions

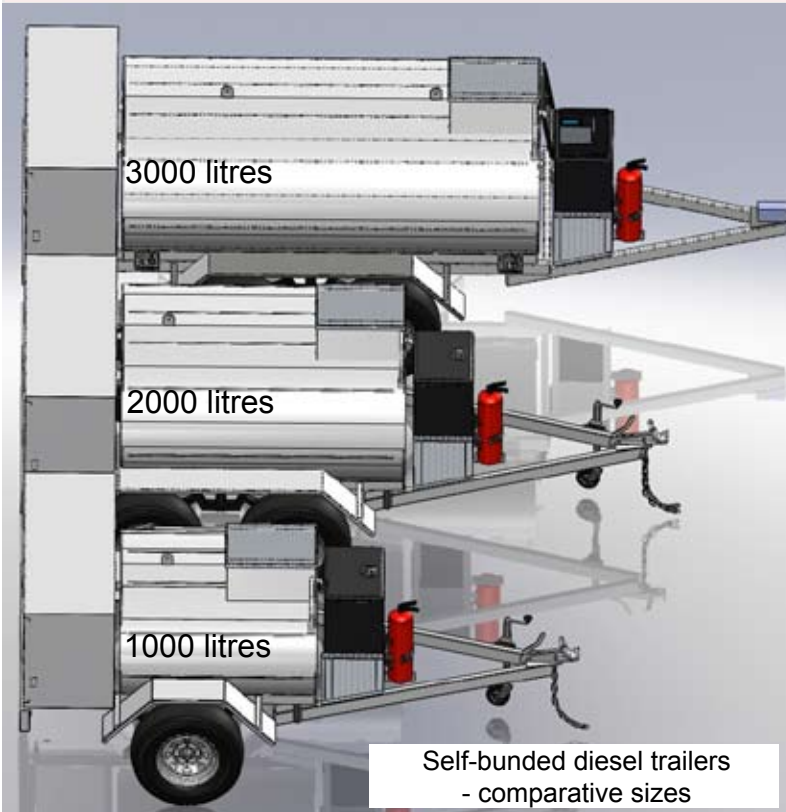

Self-bunded diesel trailers
- comparative sizes

Warranty

All equipment & workmanship fitted to these trailers are covered by 12 months warranty with additional 4 years (total 5 years) warranty on the tank. Warranty is limited to repair or replacement at our discretion and excludes normal wear & tear and physical damage caused by accident or neglect or other third party causes. No responsibility is accepted or implied for any consequential, third party damage or loss of product.

Spill Kit



Spill kit contents:

- Poly carry bag
- Absorbent GP 10 litre bag
- Absorbent GP sock 75mm x 1200mm
- Absorbent GP pillow 200mm x 450mm
- 5 x Absorbent GP pads 400mm x 500mm
- Disposal bag

Other Trailers in our Range



Dog trailer 10,000L DG Approved for Flammables - 1,2 and 3 comp.



Dangerous Goods Approved trailers for Class 3 Aviation fuel quality test & hydrant pit cleaning



Tri-compartment transformer oil with special 2 way pumping equipment



Dog trailers for diesel - reg'ble & unreg'ble



Conventional diesel trailers in 1k, 2k and 3500L versions. Reg'ble & unreg'ble with range of pumpsets

Australian Fuelling Systems & Equipment

PO Box 7162 NEMSC 2348 7-11 Armstrong Street Tamworth 2340

Ph: +61 2 6760 7816 Fax: +61 2 6760 7826

www.fuelequipment.com

Australian
FUELLING
Systems & Equipment

FUELEQUIPMENT.COM

Custom fuelling solutions

Self-Bunded Trailer Specifications

	1000 litre	2000 litre	3000 litre
Dimensions	3800L x 2030W x 1500H	4400L x 2200W x 1675H	5330L x 2200W x 1775H
Mass (tare)	1130kg	1440kg	1680kg
Mass (laden)	1980kg	3120kg	4280kg
Brakes - 12v	Electric	Electric with breakaway	Electric with breakaway
Tow hitch	50mm ball 3500kg	50mm ball 3500kg	See options
Snap-lok jockey wheel	Yes	Yes	Yes
Axle size & capacity	63mm Sq 3000kg	50mm Sq (x2) 4000kg	63mm Sq (x2) 6000kg
Plug connection type	7 pin round	12 pin flat	12 pin flat
Lights	LED multi-volt	LED multi-volt	LED multi-volt
Wheels/stud pattern	16" Sunraysia/6 stud LC	15" Sunraysia/6 stud LC	16" Sunraysia/6 stud LC
Tyres	265/75 R16	31x10.50 R15	235/85 R16
Tank capacity	1090 litres	2120 litres	3190 litres
Safe Fill Level	1035 litres (@ 95% SFL)	2000 litres	3000 litres
P & V vent with rollover shut-off valve	Treloar DPV209	Treloar DPV209	Treloar DPV209
Spill kit in lockbox	Yes	Yes	Yes
Fire extinguisher	9kg ABE with Bracket	9kg ABE with bracket	9kg ABE with bracket
Lockable pump cabinet	Yes - with drain valve	Yes - with drain valve	Yes - with drain valve
Lockable coaming	Yes	Yes	Yes
Dipstick	20x20x3mm black anodised aluminium		
Fill tube	50mm with lockable cap		
Anti-siphon valve	Yes	Yes	Yes
Interstitial monitor dipstick	Yes	Yes	Yes
Spare wheel & bracket	Option	Option	Option

About us:

We've been building fuel trailers in Tamworth, NSW, using Australian craftsmen & materials since the late 1980's - we made many mistakes, but after the first fifteen years we got to the stage where we believe we get most things right. We have designs & models for a whole range of fuel & oil handling trailers - these range from aviation refuellers, waste oil collection, special transformer oil vehicles, dog-type trailers with capabilities & volumes up to 10,000 litres for carriage of Class 3 Flammable Liquids. We even have a very task-specific vehicle which has all requirements to clean out aviation fuel hydrant pits & test the quality of the fuel at each point.

Queries:

If you have any queries on our self-bunded range or any of the other types, please call 1800-025 869 or email sales@fuelequipment.com

Australian Fuelling Systems & Equipment

PO Box 7162 NEMSC 2348 7-11 Armstrong Street Tamworth 2340

Ph: +61 2 6760 7816 Fax: +61 2 6760 7826

www.fuelequipment.com

Australian
FUELLING
Systems & Equipment