

FUELEQUIPMENT.COM

Custom fuelling solutions

Service Trailers

Our service trailers have all requirements to allow complete, safe & clean oil changes and top-ups, waste oil collection, storage & discharge, greasing, provides air power for pumps, air tools & tyre inflation, on-board power with solar recharging for electric start compressor as well as work lights. Safe & clean storage of used oil filters - with any drainage emptied into main waste oil tank.



Features - standard unit

- High quality tri-cylinder cast iron compressor with electric start petrol engine - 17cfm
- Air reel with snap-on fitting
- Waste oil system with remote collection
- Used filter drain bin
- Greasing - with K53 air cartridge gun
- 2 x new oil systems with reels & digital metering
- 1 x 200 litre stainless water or coolant tank
- Heavy duty vehicle with tandem axles, LC hubs
- Lockable storage cabinets
- Solar input to compressor start battery
- White 2 part epoxy enamel finish (custom colours optional at extra cost)
- Steps for access to tank top for fill & dip
- Aluminium guards for vehicle front and pumps
- Steel oil & waste oil tanks with spring-loaded mounts.
- Calibrated dipsticks
- Multiple air outlets for tools etc
- LED vehicle lights
- Removable spill trays
- Quality Macnaught 5:1 oil pumps
- Pneumatic double diaphragm pump for waste oil
- 9kg fire extinguisher & bracket
- Spill kit

Standard tank configuration - 2 x 200L new oils,
1 x 400L waste oil and 200L stainless water or coolant tank.

Australian Fuelling Systems & Equipment

PO Box 7162 NEMSC 2348 7-11 Armstrong Street Tamworth 2340
Ph: +61 2 6760 7816 Fax: +61 2 6760 7826

www.fuelequipment.com

Australian
FUELLING
Systems & Equipment

FUELEQUIPMENT.COM

Custom fuelling solutions

Service Trailers



Side cabinets with removable AOD pump, flow reversing valves and step ladder.



Service trailer with optional custom paint & colour



Side cabinets with used filter drain bin, waste oil collection tub & battery case

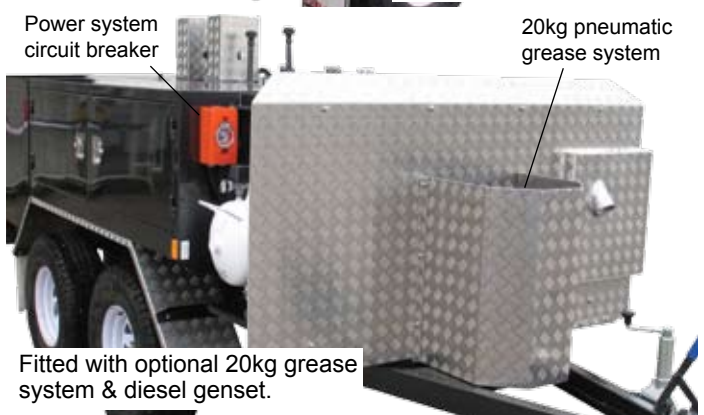

Power system circuit breaker

20kg pneumatic grease system

Fitted with optional 20kg grease system & diesel genset.

Waste Oil System

The waste oil system built into these trailers is designed so that the pump can be removed from the vehicle & carried to the waste oil source, connected to air via the air hose reel, connected to the onboard 400 litre waste oil tank via the 20mm hose reel and then easily pump the oil up to 20m's back to the trailer.

By operation of the flow reversing valve set, the onboard waste oil can be quickly and cleanly, emptied out to the depot holding tank. All connections for the oil is achieved with dry-break connections to minimise any chance of spillage.

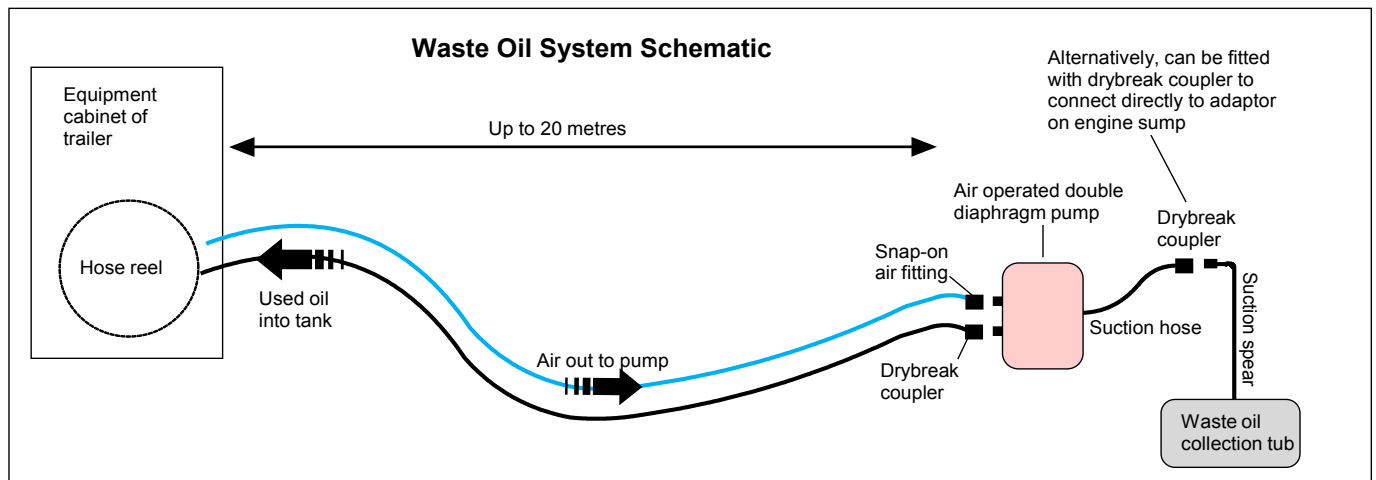

Australian Fuelling Systems & Equipment

PO Box 7162 NEMSC 2348 7-11 Armstrong Street Tamworth 2340

Ph: +61 2 6760 7816 Fax: +61 2 6760 7826

www.fuelequipment.com

**Australian
FUELLING
Systems & Equipment**

FUELEQUIPMENT.COM

Custom *fuelling* solutions

Service Trailers



Rear cabinet of a trailer equipped for 3 x new oils, cartridge grease gun, remote waste oil collection and discharge (via flow reversing valves) All oil reels are equipped with drybreak connections to allow non-spill connect/reconnect of control valves & suction tubes. Cabinet is internally lit for night operations.



20kg Grease Option

Unit at left equipped with optional lift-up doors & shows front location of optional 20kg grease system - which includes 50:1 ratio grease pump, follower plate, drum cover, grease hose reel with 10m x 6mm hose, B2 grease control valve with "Z" swivel.

These vehicles

Are designed to be below 2000kg gross mass when laden with fluids. This avoids the requirement for breakaway switching for brakes, onboard battery etc & so allows a wider range of vehicles to tow. Fitted with 7 pin flat electrical connector, 50mm ball hitch with park brake lever & safety chain.

Australian Fuelling Systems & Equipment

PO Box 7162 NEMSC 2348 7-11 Armstrong Street Tamworth 2340

Ph: +61 2 6760 7816 Fax: +61 2 6760 7826

www.fuelequipment.com

Australian
FUELLING
Systems & Equipment

FUELEQUIPMENT.COM

Custom fuelling solutions

Options & Features



Filtration units in the new oil dispensing systems as required for many QA service systems.

Full complement of Retractable hose reels in a standard trailer



Digital end-of-hose metering oil valves shown in fabricated, removable spill collection tray.



Shows Macnaught K53 pneumatic 450gm cartridge grease gun. For systems with higher greasing requirements, an optional 20kg, 50:1 system with reel can be fitted.



Shows removable air-operated double diaphragm pump, waste oil hose reel fitted with drybreak connection, 5:1 ratio oil pumps and flow reversing valves for waste oil system

Hi-pressure wash-down

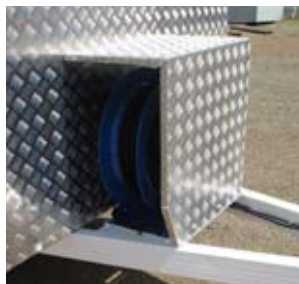

Protective cover over high pressure washdown system hose reel



Trailer fitted with high pressure washdown system, powered by electric start Yanmar diesel engine.



Please note - these are just some of the options & additional equipment specified by owners of these service trailers. Because of weight and space limitations, the range of options that can be fitted to any one trailer is limited and the inclusion of some options may preclude others.

Australian Fuelling Systems & Equipment

PO Box 7162 NEMSC 2348 7-11 Armstrong Street Tamworth 2340

Ph: +61 2 6760 7816 Fax: +61 2 6760 7826

www.fuelequipment.com

**Australian
FUELLING
Systems & Equipment**

FUELEQUIPMENT.COM

Custom fuelling solutions

Options & Features



Air pressure regulator & filter with distribution manifold. Has 3 x air outlets and water drain cock.

**Australian
designed &
manufactured**

Water system



Service trailer fitted with Honda 2Kva genset and hand-wash station.



Water delivery hose reel with faucet, 240v centrifugal water pump and outlet tap.



Quotation

Call
1800-025 869
or email
sales@fuelequipment.com
for a quotation on a service trailer for your application. Please note that we also design and build similar and larger systems that are truck mounted - these can also include diesel refuelling systems with standard top-fill or Wiggins fast-fill nozzles.
Or see our products at
www.fuelequipment.com



Macnaugh T512 5:1 ratio oil pump with protective guard.



Service trailer fitted with heavy duty rotating vice, oxy-acetylene gas bottle holders and removable air operated diaphragm pump for waste oil collection & discharge



Battery case, electric keystart for compressor and regulator from solar panel



Cabinet doors fitted with hold-open latch



Jerrycans for diesel fuel

Australian Fuelling Systems & Equipment

PO Box 7162 NEMSC 2348 7-11 Armstrong Street Tamworth 2340

Ph: +61 2 6760 7816 Fax: +61 2 6760 7826

www.fuelequipment.com

**Australian
FUELLING
Systems & Equipment**

FUELEQUIPMENT.COM

Custom fuelling solutions

Options Available

Compressor	Diesel in lieu of ULP - 5hp Yanmar with electric start, 17cfm Compac	
Genset	Petrol Honda ULP 2kva	
Genset	Diesel 2kva	
Grease	20kg with 50:1 pump system with 10m reel, gun, swivel	
Coolant	Divide stainless tank into 2 x 100 comps - 100l coolant with pump, reel & faucet	
Reels	Metal, dual pedestal in lieu of plastic	
Oil	Add tank compartment with pump, reel & digital metering gun	
Washdown	Diesel powered with lance, detergent injector, high pressure reel	
Washdown	Petrol 5hp as above	
Worklights	Adjustable with switch, 50Ah gel-type battery with case, wiring - 2 off	

Need something larger ?



We manufacture custom lube/service trucks with or without fuelling capabilities. Call for quotation



Please Note - Configuration shown here is for general illustration only. Equipment fitted & placement thereof will vary according to vehicle specifications.

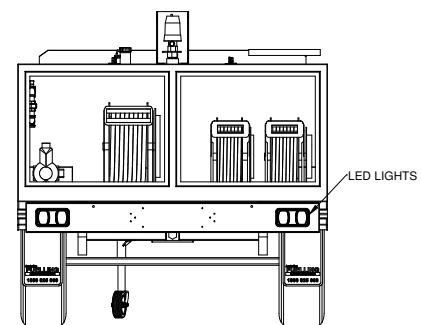
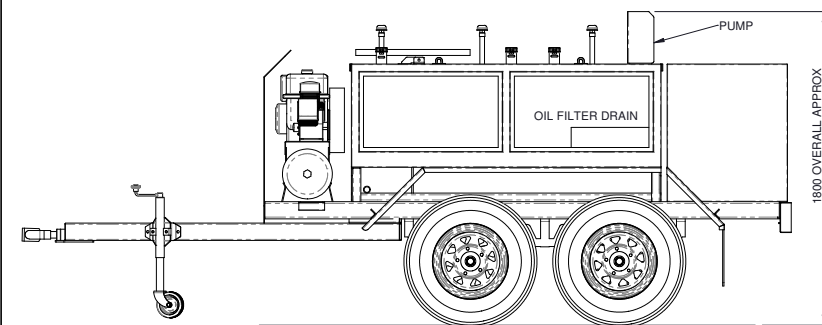
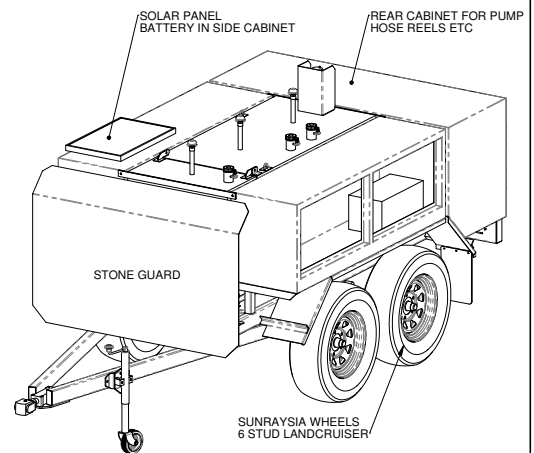
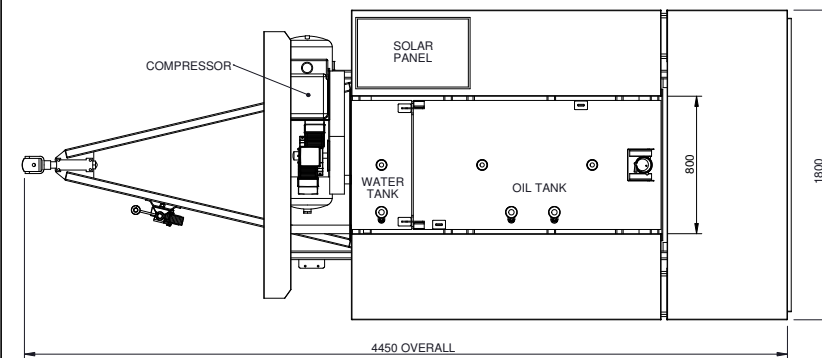

Australian Fuelling Systems & Equipment

PO Box 7162 NEMSC 2348 7-11 Armstrong Street Tamworth 2340

Ph: +61 2 6760 7816 Fax: +61 2 6760 7826

www.fuelequipment.com

Australian
FUELLING
Systems & Equipment