

Aviation Fuel Storage Tank

5,000 and 10,000 litre - low profile aluminium

Australian
FUELLING
Systems & Equipment

Constructed of 5mm marine grade aluminium plate, these tanks are specifically designed for storage of aviation fuels. Low profile elliptical design enables gravity filling from road tankers as well as being safely below rotor height.

Fittings can be installed to suit most pump systems and customer specifications.

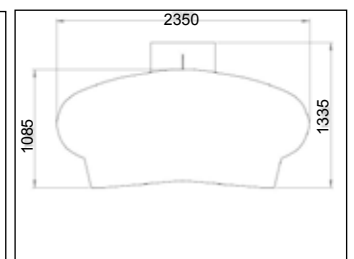
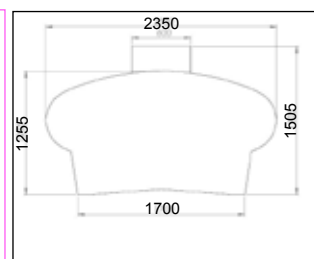
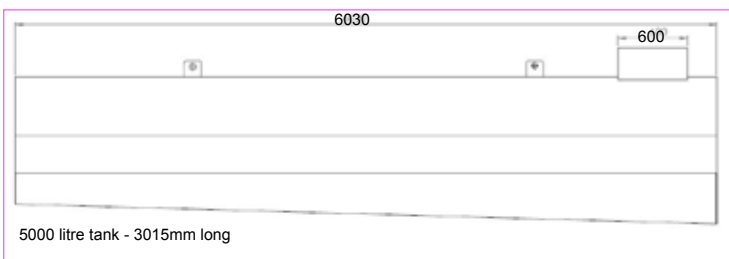
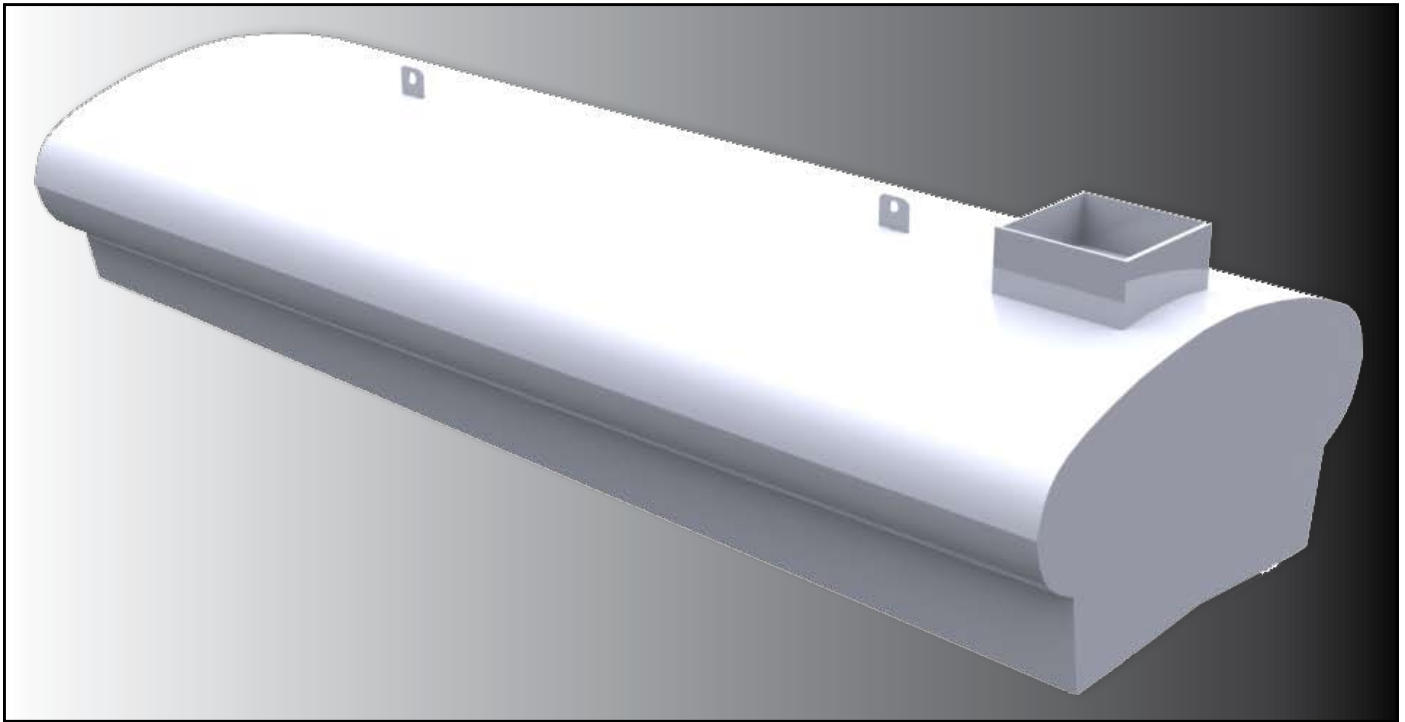

Features

30:1 sloped floor
Collection sump with stainless drain valve
80mm aluminium fill and dip tubes
P & V vent for Avgas versions
Emergency vent
Inspection hatch
Fittings for top or bottom outlet to pump
2 x Lift points fitted (empty lift only)

Man access hatch.
Spill containment at fill point.
Lockable, weatherproof enclosure over hatch.
Calibrated aluminium dipstick.
Hydro tested.
Supplied with product and HazChem signs.
9kg foam type fire extinguisher & bracket.
Available painted or unpainted

This a Cat. 3 tank not compliant to AS1692 because of materials of construction

fuelequipment.com
Liquid fuel systems & Equipment specialists

Australian Fuelling Systems & Equipment
7-11 Armstrong Street, Tamworth NSW 2340
Ph +61 2 6760 7816 - Fax +61 2 6760 7826
sales@fuel equipment.com